



Square

Ceiling Diffuser



☎ 01018875264 - 01110026664
 ✉ makkahairoutlets@gmail.com



SQUARE CEILING DIFFUSERS

GETTING YOU COMFORTABLE IS OUR CONCERN

INTRODUCTION:

Ceiling diffuser is an air outlet from an air conditioning duct, which diffuses the air over a large area to produce an even distribution and avoid drafts. Any air diffuser which is located in the ceiling is used to provide a horizontal distribution pattern of air over a zone occupied by people. Ceiling diffusers are suitable for supply air as well as exhaust air.

ETAW square ceiling diffusers providing a stable pattern of air diffusion flowing through a number of concentrically arranged sections, controlled air distribution, flow equalization, sound attenuation, architectural appearance, and solid construction.

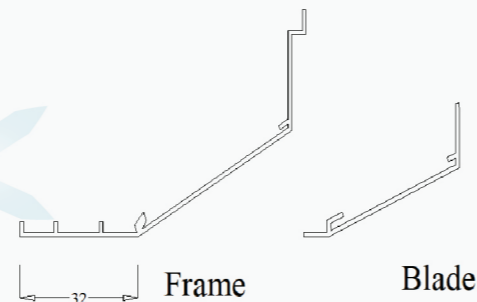
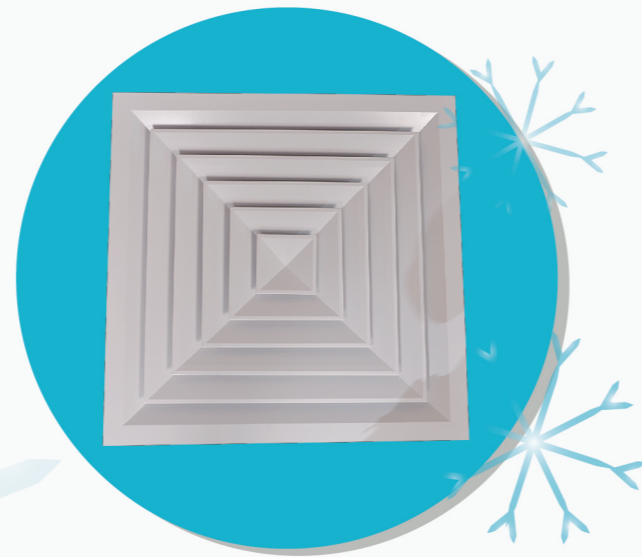

Both frame and blade are made of extruded aluminum alloy 6063. The blades are connected together by a mean of U-link in order to form the rigid core. The rigid core is connected to the frame by spring, and pins. The whole construction is making a ceiling diffuser with a removable core.

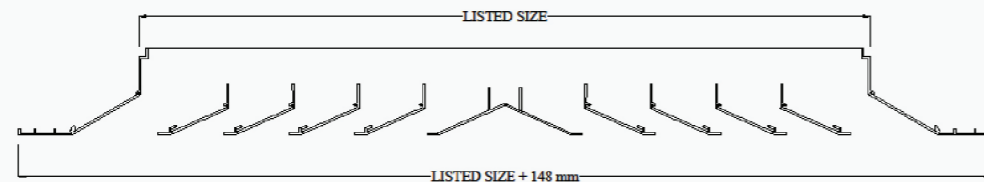

Finish

THE STANDARD FINISH OF OUR DIFFUSER IS RAL 9016 OR 9010; ANY OTHER COLOR IS AVAILABLE UPON THE CLIENT REQUEST. IT COULD BE SUPPLIED AS ANODIZED FINISH IF REQUIRED.

the frame is fixed to the false ceiling by mean of metal sheet plate .



← Press this side to compress the spring and fix the core

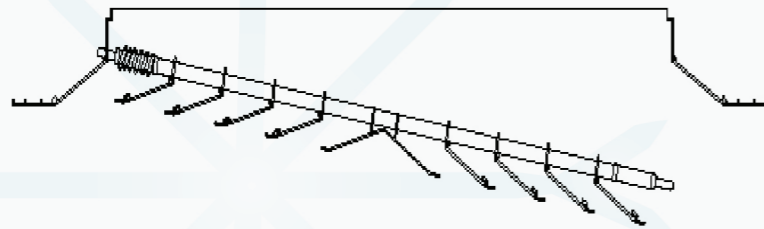

INSTALLATION:

as shown above the main frame is to be fixed to the false ceiling by a mean of metal sheet plate and screws. spring at one side and pin on the other side. We push the spring as shown in order to fix the core to the frame. By the same way we can remove the core for maintenance works or cleaning.

According to the desired function of the diffuser, it may be used as supply ceiling diffuser or be used as return/exhaust ceiling diffuser. For the supply ceiling diffuser we shall use:

OPPOSED BLADE DAMPER:

an opposed control volume damper consisting of extruded aluminum frame with extruded blades. The damper is fixed on the diffuser, on the Neck size side. The damper is controlled From the face side of the diffuser by mean of screw driver. The damper is suitable to be used in high velocity applications.

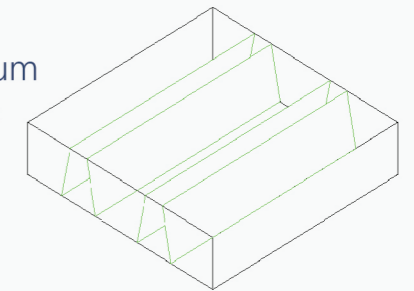

ADAPTOR:

Agalvanized steel construction designed as transition adaptor permitting the attachment of round flexible or rigid duct to square neck diffuser, and may be divided into:

SQUARE TO SQUARE

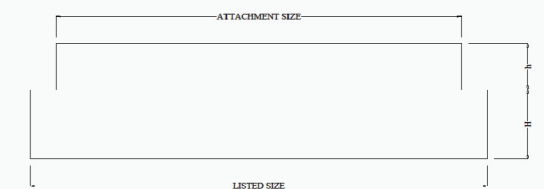

SQUARE TO ROUND

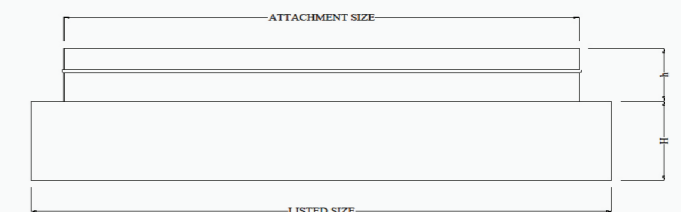



Getting you
COMFORTABLE IS OUR CONCERN

Plenum Box:

Galvanized metal sheet box with top or side inlet according to the design requirements. The top or side spigot (air inlet) can be supplied with blade damper in order to enhance air control delivered to the diffuser.

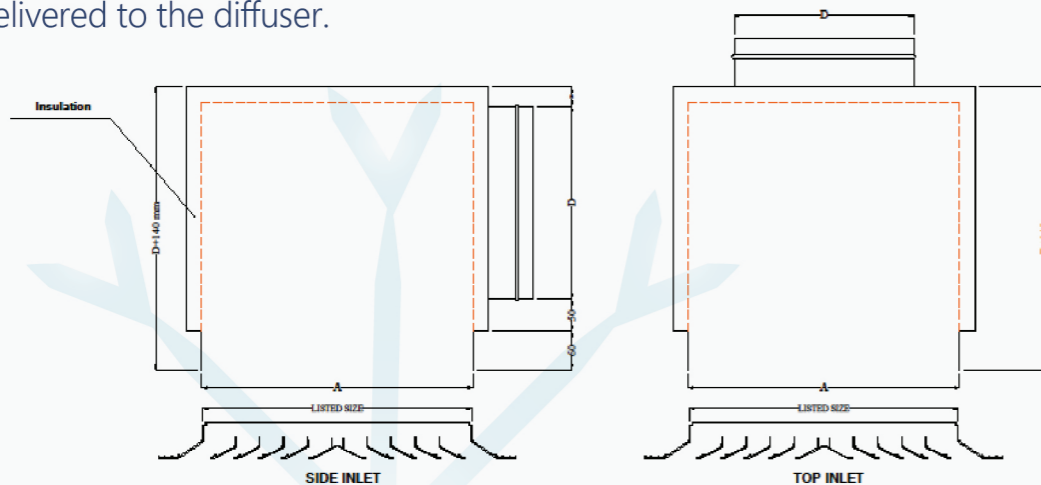

PLENUM BOX SIZING

LISTED NECK SIZE (inches)	LISTED NECK SIZE (mm)	PLENUM OPENING (A) (mm)	SPIGOT DIAMETER-D (mm)
6 X 6	150 X 150	155 X 155	100
8 X 8	200 X 200	205 X 205	150
12 X 12	300 X 300	305 X 305	200
14 X 14	350 X 350	355 X 355	250
18 X 18	450 X 450	455 X 455	300
20 X 20	500 X 500	505 X 505	350
24 X 24	600 X 600	605 X 605	400



Getting you
COMFORTABLE IS OUR CONCERN

E- ONE, TWO, THREE, FOUR WAY - RETURN

RETURN CLEANING DIFFUSER

	NECK VELOCITY	300	400	500	600	700	800	900
	VELOCITY PRESSURE	0.006	0.01	0.016	0.022	0.031	0.04	0.05
	TOTAL PRESSURE	0.042	0.075	0.117	0.169	0.229	0.3	0.379
SIZE Ak(ft ²)								
6" X 6" (0.25)	CFM	75	100	125	150	175	200	225
	NC	-	14	17	24	28	32	35
	THROW	-	-	-	-	-	-	-
8" X 8" (0.56)	CFM	169	225	281	338	394	450	506
	NC	-	16	22	27	31	35	38
	THROW	-	-	-	-	-	-	-
12" X 12" (1)	CFM	300	400	500	600	700	800	900
	NC	-	18	24	29	33	36	39
	THROW	-	-	-	-	-	-	-
14" X 14" (1.56)	CFM	469	625	781	938	1094	1250	1406
	NC	12	20	26	30	34	38	41
	THROW	-	-	-	-	-	-	-
16" X 16" (1.75)	CFM	525	700	875	1050	1225	1400	1575
	NC	13	20	26	31	35	38	41
	THROW	-	-	-	-	-	-	-
18" X 18" (2.25)	CFM	675	900	1125	1350	1575	1800	2025
	NC	13	21	27	32	36	39	42
	THROW	-	-	-	-	-	-	-
20" X 20" (3.06)	CFM	919	1225	1531	1838	2144	2450	2756
	NC	14	22	28	33	37	40	43
	THROW	-	-	-	-	-	-	-
22" X 22" (3.5)	CFM	1050	1400	1750	2100	2450	2800	3150
	NC	15	22	28	33	37	41	44
	THROW	-	-	-	-	-	-	-
24" X 24" (4)	CFM	1200	1600	2000	2400	2800	3200	3600
	NC	15	23	29	32	37	41	44
	THROW	-	-	-	-	-	-	-

* All pressures are in inches of water.

** NC values are based on a room absorption of 10 dB, re 10⁻¹² watts, with one diffuser operating.

● for NC < 20 ● for NC 20-30 ● for NC 30-40 ● for NC > 40



Getting you

COMFORTABLE IS OUR CONCERN



D- FOUR WAY - SUPPLY

SUPPLY CEILING DIFFUSER - 4 WAY - SUPPLY

	NECK VELOCITY	300	400	500	600	700	800	900
	VELOCITY PRESSURE	0.006	0.01	0.016	0.022	0.031	0.04	0.05
	TOTAL PRESSURE	0.042	0.075	0.117	0.169	0.229	0.3	0.379
SIZE Ak(ft²)								
6" X 6" (0.25)	CFM	75	100	125	150	175	200	225
	NC	-	13	16	23	27	31	34
	THROW	03-05-08	04-07-09	06-07-10	07-08-11	07-09-12	08-09-13	08-10-14
8" X 8" (0.56)	CFM	169	225	281	338	394	450	506
	NC	-	15	21	26	30	34	37
	THROW	04-07-12	07-10-14	08-11-16	10-12-17	11-13-18	11-14-20	12-15-21
12" X 12" (1)	CFM	300	400	500	600	700	800	900
	NC	-	17	23	28	32	35	38
	THROW	06-10-16	9-13-19	11-15-21	13-16-23	14-17-25	15-19-26	16-20-28
14" X 14" (1.56)	CFM	469	625	781	938	1094	1250	1406
	NC	11	19	25	29	33	37	40
	THROW	07-12-20	11-16-23	14-18-26	16-20-23	18-22-31	19-23-33	20-23-35
16" X 16" (1.75)	CFM	525	700	875	1050	1225	1400	1575
	NC	12	19	25	30	34	37	40
	THROW	9-14-23	13-19-26	16-21-29	19-23-32	20-25-35	21-26-37	23-28-39
18" X 18" (2.25)	CFM	675	900	1125	1350	1575	1800	2025
	NC	12	20	26	31	35	38	41
	THROW	9-15-24	13-20-28	17-22-31	20-24-34	21-26-37	23-28-39	24-30-42
20" X 20" (3.06)	CFM	919	1225	1531	1838	2144	2450	2756
	NC	13	21	27	32	36	39	42
	THROW	10-17-28	16-23-32	19-26-36	23-28-40	25-30-43	27-32-46	28-34-49
22" X 22" (3.5)	CFM	1050	1400	1750	2100	2450	2800	3150
	NC	14	21	27	32	36	40	43
	THROW	13-20-32	18-26-37	22-29-41	26-32-45	28-35-49	30-37-52	32-39-56
24" X 24" (4)	CFM	1200	1600	2000	2400	2800	3200	3600
	NC	14	22	28	32	36	40	43
	THROW	12-20-23	18-26-37	22-29-41	26-32-45	28-35-49	30-37-52	32-39-56

* All pressures are in inches of water.
 ** Throw values are given for terminal velocities of 150, 100, and 50 fpm.
 *** NC values are based on a room absorption of 10 dB, re 10⁻¹² watts, with one diffuser operating.
 ● for NC < 20 ● for NC 20-30 ● for NC 30-40 ● for NC > 40



Getting you

COMFORTABLE IS OUR CONCERN

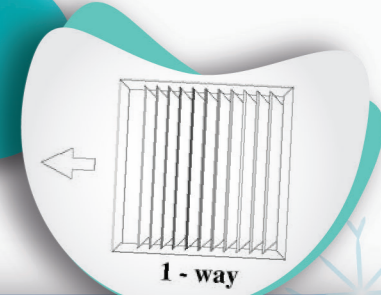

PERFORMANCE DATA:
A - ONE - SUPPLY

SUPPLY CEILING DIFFUSER - 1 WAY - SUPPLY

	NECK VELOCITY	300	400	500	600	700	800	900
	VELOCITY PRESSURE	0.006	0.01	0.016	0.022	0.031	0.04	0.05
	TOTAL PRESSURE	0.042	0.075	0.117	0.169	0.299	0.3	0.379
SIZE AK(FT²)								
6" X 6" (0.25)	CFM	75	100	125	150	175	200	225
	NC	-	13	16	23	27	31	34
	THROW	08-10-14	09-11-16	10-13-18	11-14-20	12-15-21	13-16-23	14-17-24
8" X 8" (0.56)	CFM	169	225	281	338	394	450	506
	NC	-	15	21	26	30	34	37
	THROW	11-15-21	14-17-24	16-19-27	17-21-30	18-23-32	20-24-34	21-26-36
12" X 12" (1)	CFM	300	400	500	600	700	800	900
	NC	-	17	23	28	32	35	38
	THROW	15-20-28	19-23-32	21-25-36	23-28-39	25-30-43	26-32-46	28-34-48
14" X 14" (1.56)	CFM	469	625	781	938	1094	1250	1406
	NC	11	19	25	29	33	37	40
	THROW	19-25-35	23-29-40	26-32-45	29-35-49	31-38-53	33-40-57	35-43-60
16" X 16" (1.75)	CFM	525	700	875	1050	1225	1400	1575
	NC	12	19	25	30	34	37	40
	THROW	23-28-29	26-32-45	29-36-51	32-39-56	35-43-60	37-45-64	39-48-68
18" X 18" (2.25)	CFM	675	900	1125	1350	1575	1800	2025
	NC	12	20	26	31	35	38	41
	THROW	23-30-42	28-34-48	31-38-54	34-42-59	37-45-64	39-48-68	42-51-73
20" X 20" (3.06)	CFM	919	1225	1531	1838	2144	2450	2756
	NC	13	21	27	32	36	39	42
	THROW	27-35-49	33-40-56	36-45-63	40-49-96	43-53-75	46-56-80	49-60-85
22" X 22" (3.5)	CFM	1050	1400	1750	2100	2450	2800	3150
	NC	14	21	27	32	36	40	43
	THROW	32-39-56	37-45-64	42-51-72	45-56-79	49-60-85	53-64-91	56-68-97
24" X 24" (4)	CFM	1200	1600	2000	2400	2800	3200	3600
	NC	14	22	28	32	36	40	43
	THROW	31-39-56	37-46-64	42-51-72	46-56-79	49-60-85	53-64-91	56-68-97

* All pressures are in inches of water.
 ** Throw values are given for terminal velocities of 150, 100, and 50 fpm.
 *** NC values are based on a room absorption of 10 dB, re 10⁻¹² watts, with one diffuser operating.
 ● for NC < 20 ● for NC < 20 ● for NC 30-40 ● for NC > 40



Getting you

COMFORTABLE IS OUR CONCERN

B - TWO WAY - SUPPLY

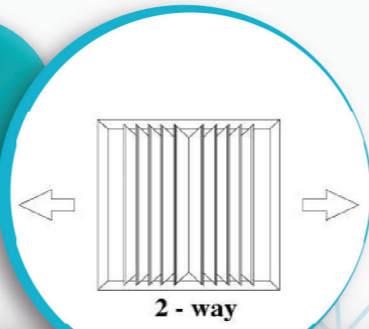

SUPPLY CEILING DIFFUSER - 2 WAY - SUPPLY

	NECK VELOCITY	300	400	500	600	700	800	900
	VELOCITY PRESSURE	0.006	0.01	0.016	0.022	0.031	0.04	0.05
	TOTAL PRESSURE	0.042	0.075	0.117	0.169	0.299	0.3	0.379
SIZE AK(FT ²)								
6" X 6" (0.25)	CFM	75	100	125	150	175	200	225
	NC	-	13	16	23	27	31	34
	THROW	04-06-10	05-08-12	06-10-14	08-10-15	09-11-16	10-12-17	10-13-19
8" X 8" (0.56)	CFM	169	225	281	338	394	450	506
	NC	-	15	21	26	30	34	37
	THROW	06-09-16	08-11-18	10-14-20	11-16-22	13-17-24	15-18-26	16-19-27
12" X 12" (1)	CFM	300	400	500	600	700	800	900
	NC	-	17	23	28	32	35	38
	THROW	08-11-21	10-15-24	13-19-27	15-21-30	18-32-32	20-24-34	21-26-36
14" X 14" (1.56)	CFM	469	625	781	938	1094	1250	1406
	NC	11	19	25	29	33	37	40
	THROW	10-14-26	13-19-30	16-24-34	19-26-37	22-28-40	25-30-43	26-32-45
16" X 16" (1.75)	CFM	525	700	875	1050	1225	1400	1575
	NC	12	19	25	30	34	37	40
	THROW	12-19-32	17-25-37	21-30-42	25-32-46	29-35-50	31-37-53	32-40-56
18" X 18" (2.25)	CFM	675	900	1125	1350	1575	1800	2025
	NC	12	20	26	31	35	38	41
	THROW	11-17-31	15-23-36	19-29-41	23-31-44	27-34-48	30-36-51	31-45-63
20" X 20" (3.06)	CFM	919	1225	1531	1838	2144	2450	2756
	NC	13	21	27	32	36	39	42
	THROW	13-20-37	18-27-42	22-33-47	27-37-52	31-40-56	35-42-60	37-45-63
22" X 22" (3.5)	CFM	1050	1400	1750	2100	2450	2800	3150
	NC	14	21	27	32	36	40	43
	THROW	18-26-46	23-35-53	29-42-59	35-46-65	40-50-70	43-53-75	56-68-97
24" X 24" (4)	CFM	1200	1600	2000	2400	2800	3200	3600
	NC	14	22	28	32	36	40	43
	THROW	15-23-42	20-30-48	25-38-54	30-42-59	35-45-64	39-48-68	42-51-72

* All pressures are in inches of water.
 ** Throw values are given for terminal velocities of 150, 100, and 50 fpm.
 *** NC values are based on a room absorption of 10 dB, re 10⁻¹² watts, with one diffuser operating.
 ● for NC < 20 ● for NC < 20-30 ● for NC 30-40 ● for NC > 40



Getting you

COMFORTABLE IS OUR CONCERN

C - THREE WAY - SUPPLY

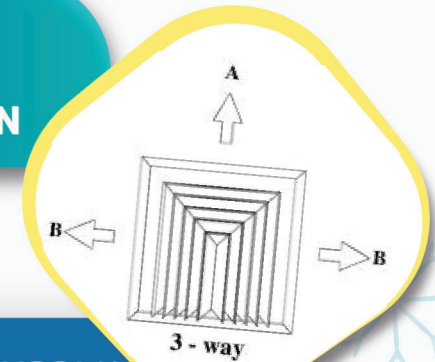

SUPPLY CEILING DIFFUSER - 3 WAY - SUPPLY

	NECK VELOCITY	300	400	500	600	700	800	900
	VELOCITY PRESSURE	0.006	0.01	0.016	0.022	0.031	0.04	0.05
	TOTAL PRESSURE	0.042	0.075	0.117	0.169	0.299	0.3	0.379
SIZE AK(FT ²)								
6" X 6" (0.25)	CFM	75	100	125	150	175	200	225
	NC	-	13	16	23	27	31	34
	THROW	A 04-06-09 B 03-05-08	05-07-11 04-07-09	06-08-12 06-07-10	07-09-13 07-08-11	08-10-14 07-09-12	09-11-15 08-09-13	09-11-16 08-10-14
8" X 8" (0.56)	CFM	169	225	281	338	394	450	506
	NC	-	15	21	26	30	34	37
	THROW	A 08-10-14 B 04-07-12	09-11-16 07-10-14	10-13-18 08-11-16	11-14-20 10-12-17	12-15-21 11-13-18	13-16-23 11-14-20	14-17-24 12-15-21
12" X 12" (1)	CFM	300	400	500	600	700	800	900
	NC	-	17	23	28	32	35	38
	THROW	A 11-13-18 B 06-10-16	12-15-21 9-13-19	14-17-24 11-15-21	15-18-26 13-16-23	16-20-28 14-17-25	17-21-30 15-19-26	18-23-32 16-20-28
14" X 14" (1.56)	CFM	469	625	781	938	1094	1250	1406
	NC	11	19	25	29	33	37	40
	THROW	A 13-16-23 B 07-12-20	15-19-27 11-16-23	17-21-30 14-18-26	19-23-33 16-20-28	20-25-35 18-22-31	22-27-38 19-23-33	20-25-35 28-34-48
16" X 16" (1.75)	CFM	525	700	875	1050	1225	1400	1575
	NC	12	19	25	30	34	37	40
	THROW	A 14-21-29 B 9-14-23	19-24-34 13-19-20	22-27-38 16-21-29	24-29-41 19-23-32	26-32-45 20-25-35	28-34-48 21-26-37	29-36-51 23-28-39
18" X 18" (2.25)	CFM	675	900	1125	1350	1575	1800	2025
	NC	12	20	26	31	35	38	41
	THROW	A 16-20-28 B 9-15-24	18-23-32 13-20-28	21-25-36 17-22-31	23-28-39 20-24-34	24-30-42 21-26-37	26-32-45 23-28-39	28-34-48 24-30-42
20" X 20" (3.06)	CFM	919	1225	1531	1838	2144	2450	2756
	NC	13	21	27	32	36	39	42
	THROW	A 19-23-32 B 10-17-28	22-26-37 16-23-32	24-30-42 19-26-36	26-32-46 23-28-40	29-35-49 25-30-43	31-37-53 27-32-46	32-40-56 28-34-49
22" X 22" (3.5)	CFM	1050	1400	1750	2100	2450	2800	3150
	NC	14	21	27	32	36	40	43
	THROW	A 20-29-41 B 13-20-32	26-34-48 18-26-37	31-38-53 22-29-41	34-41-59 26-32-45	37-45-63 28-35-49	39-48-68 30-37-52	41-51-72 32-39-56
24" X 24" (4)	CFM	1200	1600	2000	2400	2800	3200	3600
	NC	14	22	28	32	36	40	43
	THROW	A 21-26-37 B 12-20-32	25-30-43 18-26-37	28-34-48 22-29-41	30-37-52 26-32-45	33-40-56 28-35-49	35-43-60 30-37-52	37-45-64 32-39-56

* All pressures are in inches of water.
 ** Throw values are given for terminal velocities of 150, 100, and 50 fpm.
 *** NC values are based on a room absorption of 10 dB, re 10⁻¹² watts, with one diffuser operating.
 ● for NC < 20 ● for NC < 20-30 ● for NC 30-40 ● for NC > 40